



# NOVO MAKINA

WOODWORKING



# PRODUCT CATALOG







# NOVO MAKİNA

WOODWORKING

 Mesudiye Mah. Yıldırım Cad.  
No:49 İnegöl - BURSA / TÜRKİYE

 [www.novomakina.com](http://www.novomakina.com)  
[info@novomakina.com](mailto:info@novomakina.com)

 +90 224 716 06 46  
+90 551 202 04 30





**EXPORT**

NOVO MASHINA

# Novo MAKİNA

Novo Makina olarak, ağaç işleme sektöründe öncü ve kapsamlı çözümler sunmak için azami gayretle çalışıyoruz. Tasarım, üretim, montaj, danışmanlık ve servis gibi geniş hizmet yelpazemizle müşteri ihtiyaçlarına uygun çözümleri taahhüt ediyoruz.

Teknolojik yenilikleri yakından takip ederek güçlü uzman kadromuzla sürekli gelişimi amaçlıyoruz. Amacımız, müşterilerimizin taleplerini anlayarak en son teknolojiyle donatılmış ürünler sunarak işletmelerinin verimliliğini artırmaktır.

Müşteri memnuniyeti bizim önceliğimizdir. Geniş ürün yelpazemiz sayesinde farklı sektörlerdeki müşterilere çeşitli çözümler sunuyoruz. Kaliteyi ön planda tutarak müşteri güvenini kazanmak ve uzun süreli iş birlikleri oluşturmak en büyük hedefimizdir.

İhracat kapasitemizi artırma ve global pazarda adımızı duyurma çabası içindeyiz. Uluslararası alanda saygın bir marka olma hedefiyle dünya trendlerini yakından takip ediyoruz.

Müşterilerimizin bizi çözüm ortağı olarak görmesi gurur kaynağımızdır. Destekleri için tüm müşterilerimize teşekkür ediyoruz. Sizi de Novo Makina ailesine çözüm ortağı olarak davet ediyoruz. Sorularınız ve iş birliği teklifleriniz için her zaman bizimle iletişime geçebilirsiniz.

Saygılarımızla,

At Novo Machinery, we strive with utmost effort to provide pioneering and comprehensive solutions in the wood processing sector. With a broad range of services including design, production, assembly, consultancy, and service, we commit to delivering solutions tailored to customer needs.

By closely following technological innovations and aiming for continuous improvement with our strong team of experts, our goal is to enhance business efficiency by understanding customer requirements and offering products equipped with the latest technology.

Customer satisfaction is our priority. Through our wide product range, we offer various solutions to customers in different sectors, emphasizing quality to gain their trust and establish long-term collaborations.

We are dedicated to increasing our export capacity and making our name known in the global market. With the aim of becoming a reputable brand internationally, we closely monitor global trends.

It's a source of pride for us that our customers see us as solution partners. We extend our gratitude to all customers for their support. We invite you to join the Novo Machinery family as a solution partner. For your questions and collaboration proposals, you can always reach out to us.

Regards,



## İÇERİK / INDEX

ÇOKLU DİLİMLEME MAKİNESİ MULTIPLE RIP SAW MACHINE CKDM 160	03
ÇOKLU DİLİMLEME MAKİNESİ MULTIPLE SLICING MACHINE CKDM 120	05
ÇOKLU DİLİMLEME MAKİNESİ MULTIPLE SLICING MACHINE CKDM 120-B	07
PALETLİ ÇOKLU DİLİMLEME MAKİNESİ PALLET MULTIPLE SLICING MACHINE PCDM-120	09
KENAR ALMA MAKİNESİ EDGE TRIMMING MACHINE KAM S80	11
BOY KESME MAKİNESİ VERTICAL CUTTING MACHINE NBK-300	13
MANUEL BOY KESME MAKİNESİ MANUAL CUT TO LENGTH MACHINE NBM	15
TAKOZ KESME MAKİNESİ WEDGE CUTTING MACHINE NTKM - 150	17
PAPEL PRESS MAKİNESİ PAPEL PRESS MACHINE PPM-220	19
PAPEL PRESS MAKİNESİ PAPEL PRESS MACHINE PPM-B-220	21
ZIVANA EZME MAKİNESİ TENTLE CRUSHING MACHINE ZEM M50	23
DİKEY SÜNGER KESME MAKİNESİ VERTICAL FOAM CUTTING MACHINE DSK 240	25
MANUEL PALET ÇAKIM TEZGAHI MANUAL PALLET HITTING MACHINE NPC 1400	27

# ÇOKLU DİLİMLEME MAKİNESİ MULTIPLE SLICING MACHINE



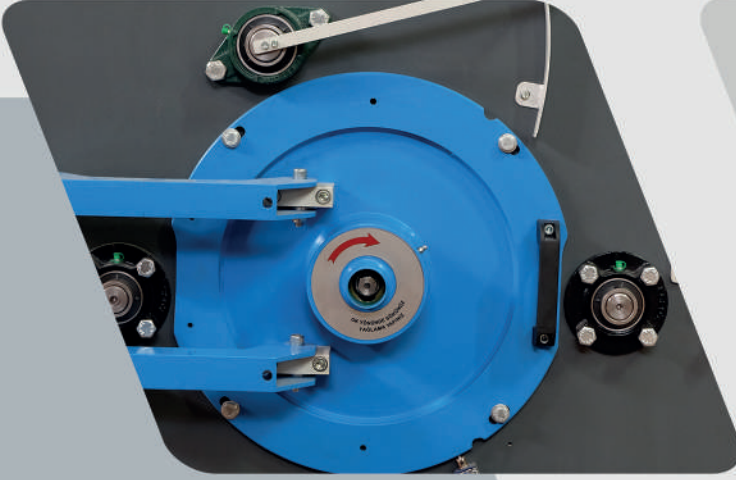

## ÖZELLİKLER / SPECIFICATIONS

Kesme Yüksekliği	Cutting Height	: Min: 10mm - Max: 160mm
Mil Kullanım Alanı	Spindle Usage Area	: Max: 750mm
Daire Testere Mil Motoru	Circular Saw Spindle Motor	: Max: 55 kW
Daire Testere Sayısı	Number of Circular Saws	: Max: 15 Ad.
Daire Testere Göbek Çapı	Circular Saw Arbor Diameter	: Standart 70 mm
Daire Testere Çapı	Circular Saw Diameter	: Min: 200mm - Max: 450mm
Ağırlık	Weight	: 1850 Kg.
Besleme	Feeding	: Manuel & Otomatik
Elektrik Kapasitesi	Electrical Capacity	: Max: 57 kW

**Not:** \* Makine testere aralıkları, müşteri isteklerine göre opsiyoneldir.

\* Çalışma güvenliği sağlayan alt ve üst siperler

\* Hidrolik baskılı,bağımsız ve hareketli merdaneler

\* Talaş bandı opsiyoneldir. \* Mazotlama Sistemi opsiyoneldir.

**Note:** \* Machine saw ranges are subject to customer requirements is optional.

\*Movable finger iron platers for safe guidance and protection.

\*Hydraulic upper roller pressure and movable clinders.

\* Sawdust band is optional. \* Fueling System is optional.

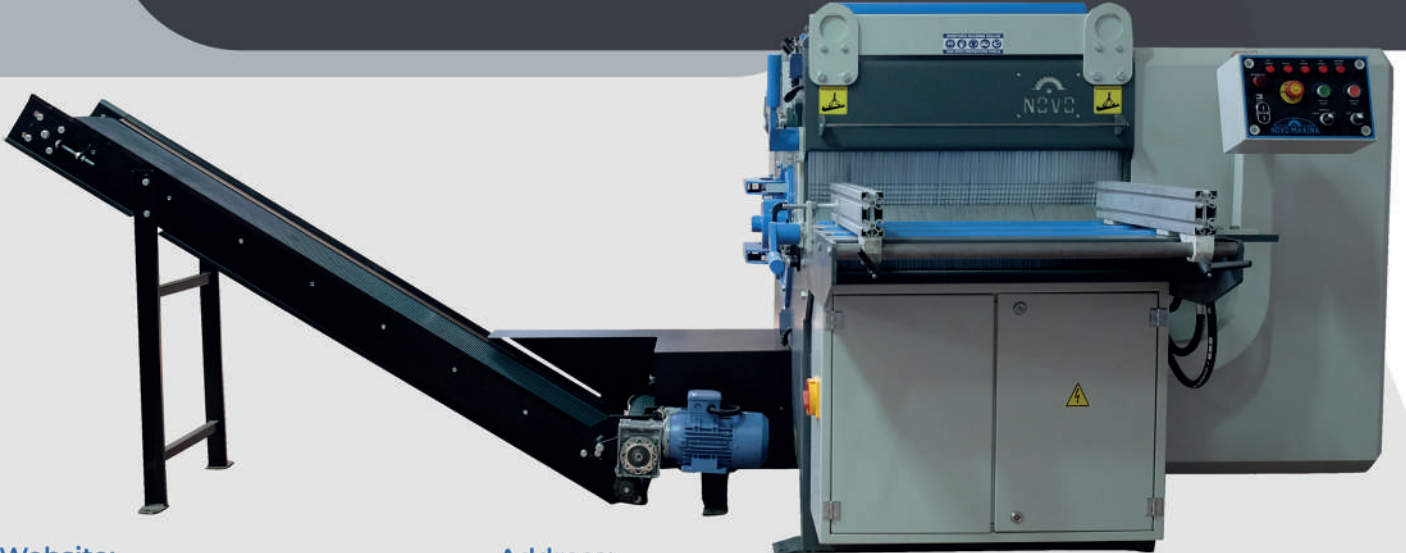

# ÇOKLU DİLİMLEME MAKİNESİ MULTIPLE SLICING MACHINE





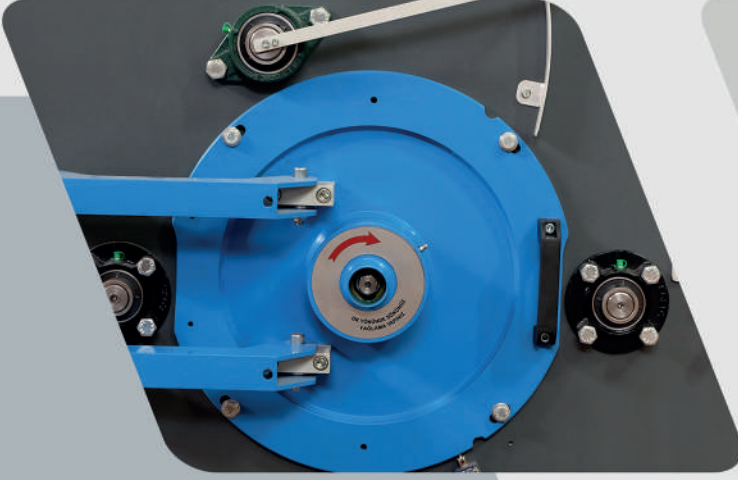

## ÖZELLİKLER / SPECIFICATIONS

Kesme Yüksekliği	Cutting Height	: Min: 10mm - Max: 120mm
Mil Kullanım Alanı	Spindle Usage Area	: Max: 360mm
Daire Testere Mil Motoru	Circular Saw Spindle Motor	: Max: 37 kW
Daire Testere Sayısı	Number of Circular Saws	: Max: 15 Ad.
Daire Testere Göbek Çapı	Circular Saw Arbor Diameter	: Standart 70 mm
Daire Testere Çapı	Circular Saw Diameter	: Min: 200mm - Max: 350mm
Ağırlık	Weight	: 1850 Kg.
Besleme	Feeding	: Manuel & Otomatik
Elektrik Kapasitesi	Electrical Capacity	: Max: 39 kW

**Not:** \* Makine testere aralıkları, müşteri isteklerine göre opsiyoneldir.

\* Talaş bandı opsiyoneldir. \* Mazotlama Sistemi opsiyoneldir.

**Note:** \* Machine saw intervals are optional based on customer requests.

\* Sawdust band is optional. \* Fueling System is optional.



# ÇOKLU DİLİMLEME MAKİNESİ MULTIPLE RIP SAW MACHINE

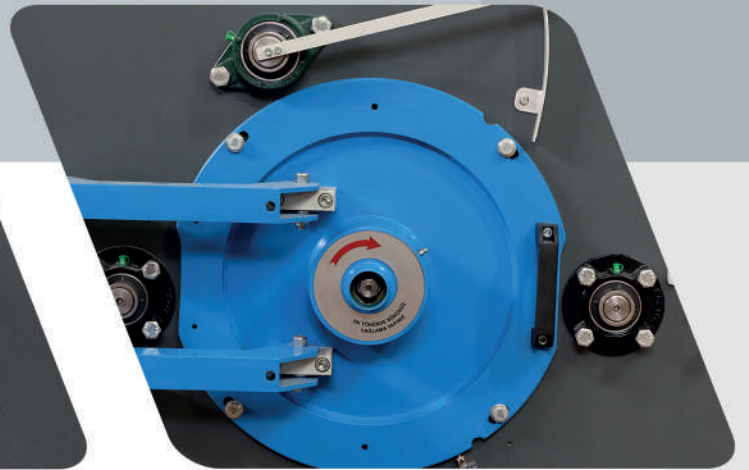
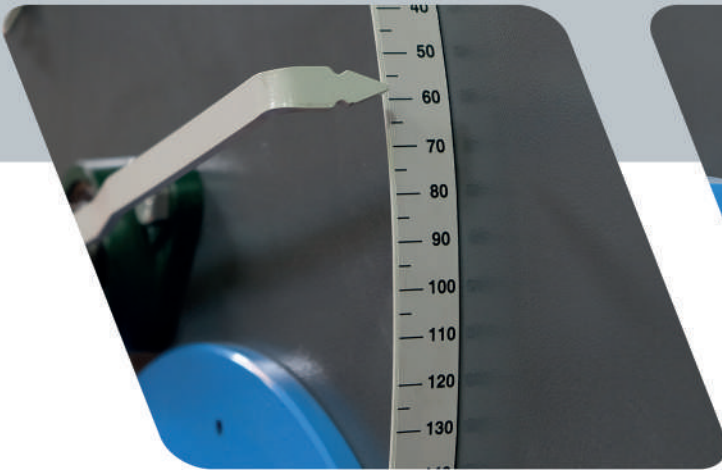

Phone:  
+90 224 716 06 46

Mail:  
info@novomakina.com



## ÖZELLİKLER / SPECIFICATIONS

Kesme Yüksekliği	Cutting Height	: Min: 10mm - Max: 120mm
Mil Kullanım Alanı	Spindle Usage Area	: Max: 750mm
Daire Testere Mil Motoru	Circular Saw Spindle Motor	: Max: 37 kW
Daire Testere Sayısı	Number of Circular Saws	: Max: 15 Ad.
Daire Testere Göbek Çapı	Circular Saw Core Diameter	: Standart 70 mm
Daire Testere Çapı	Circular Saw Diameter	: Min: 200mm - Max: 350mm
Ağırlık	Weight	: 1450 Kg.
Besleme	Feed	: Manuel & Otomatik
Elektrik Kapasitesi	Electrical Capacity	: Max: 39 kW

\* Giriş Lata pnömatik baskı merdanesi  
\* Input Lata pneumatic pressure roller

Not: \* Makine testere aralıkları, müşteri isteklerine göre opsiyoneldir.  
\* Çalışma güvenliği sağlayan alt ve üst siperler  
\* Hidrolik baskılı,bağımsız ve hareketli merdaneler

Note: \* Machine saw ranges are subject to customer requirements is optional.  
\*Movable finger iron platers for safe guidance and protection.  
\*Hydraulic upper roller pressure and movable clinders.



# PALETLİ ÇOKLU DİLİMLEME MAKİNESİ PALLET MULTIPLE SLICING MACHINE





## ÖZELLİKLER / SPECIFICATIONS

Kesme Yüksekliği	Cutting Height	: Min: 10mm - Max: 120mm
Mil Kullanım Alanı	Spindle Usage Area	: Max: 360mm
Daire Testere Mil Motoru	Circular Saw Spindle Motor	: Max: 37 kW
Daire Testere Sayısı	Number of Circular Saws	: Max: 6 Ad.
Daire Testere Göbek Çapı	Circular Saw Arbor Diameter	: Standart 70 mm
Daire Testere Çapı	Circular Saw Diameter	: Min: 200mm - Max: 350mm
Ağırlık	Weight	: 1850 Kg.
Besleme	Feeding	: Manuel & Otomatik
Elektrik Kapasitesi	Electrical Capacity	: Max: 39 kW

Not: \* Makine testere aralıkları, müşteri isteklerine göre opsiyoneldir.

Note: \* Machine saw intervals are optional based on customer requests.



# KENAR ALMA MAKİNESİ EDGE TRIMMING MACHINE



Phone:  
+90 224 716 06 46

Mail:  
info@novomakina.com



## ÖZELLİKLER / SPECIFICATIONS

Kesme Yüksekliği	Cutting Height S	: Min: 10mm - Max: 80mm
Testere Çapı	Saw Diameter	: Max: 300mm
Testere Sayısı	Number of Saws	: Max: 15 Ad.
Testere Göbek Çapı	Saw Core Diameter	: Standart 70 mm
Ağırlık	Weight	: 1050 Kg.
Elektrik Kapasitesi	Electric Capacity	: Max: 13 kW

Not: \* Makine testere aralıkları, müşteri isteklerine göre opsiyoneldir.

\* Çalışma güvenliği sağlayan alt ve üst spiperler

\* Hassas kesim kalitesi. \* Basit kurulum mekanizması.

\* Bağımsız ve hareketli merdaneler. \* Max. 15 testere dilimleme.

Note: \* Machine saw intervals are optional based on customer requests.

\* Lower and upper spacers ensuring operational safety.

\* Precise cutting quality. \* Simple installation mechanism.

\* Independent and movable rollers. \* Maximum 15-blade slicing capability.

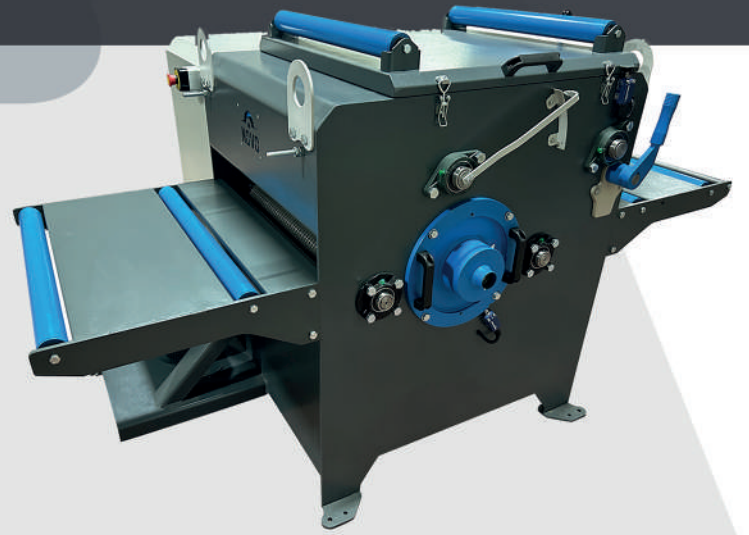

# BOY KESME MAKİNESİ VERTICAL CUTTING MACHINE

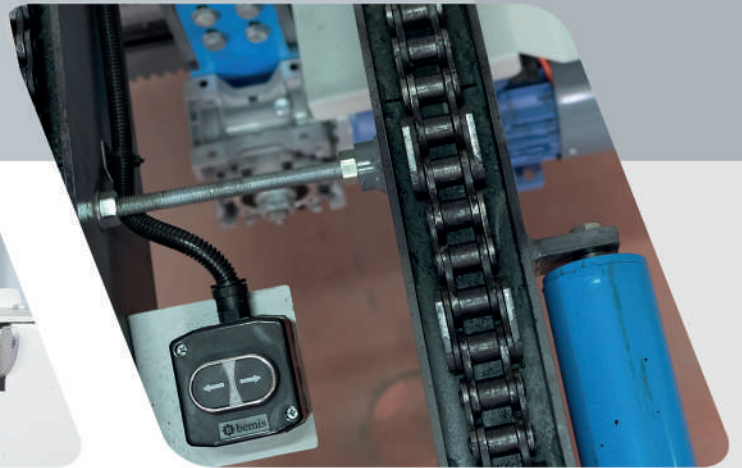



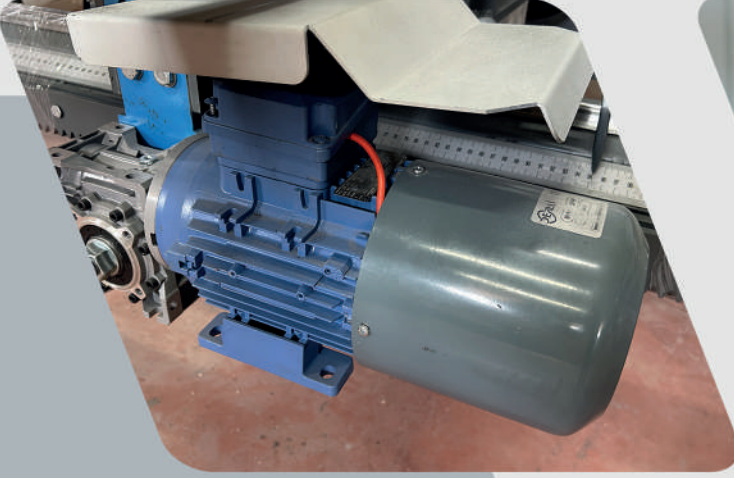

## ÖZELLİKLER / SPECIFICATIONS

Kesme Uzunluğu	Cutting Length	: Min: 420mm - Max: 6000mm
Kesme Yüksekliği	Cutting Height	: Max: 200mm
Kesme Geniřlięi	Cutting Width	: Min: 500mm
Motor Gücü	Motor Power	: 5.5 kW - 7.5 kW - 11 kW
Toplam Güç	Total Power	: 59 kW (5 Blades) 29 kW (4 Blades) 18 kW (3 Blades) 12 kW (2 Blades)

**Not: \* Müřteri isteęine göre yükseklik ve boy uzunlukları opsiyonel olarak ayarlanmaktadır.**

**Note: \* Heights and lengths can be optionally adjusted according to customer's request.**

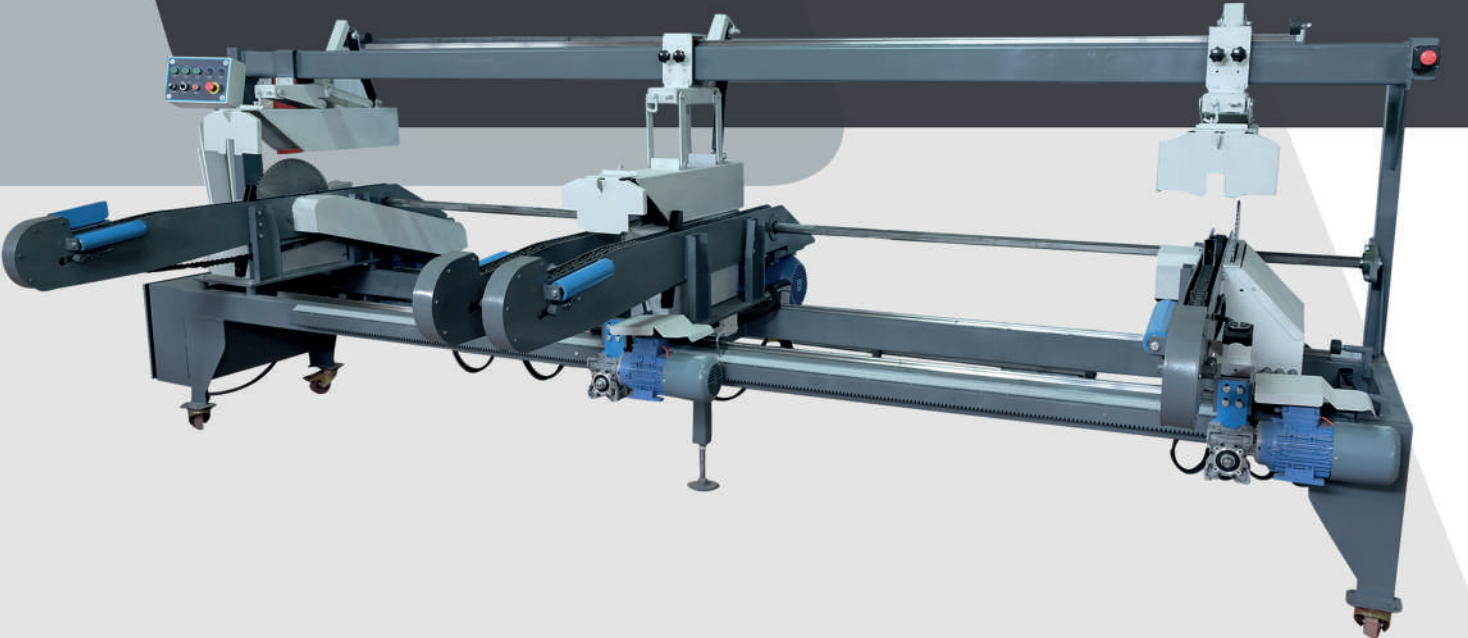

# MANUEL BOY KESME MAKİNESİ MANUAL CUT TO LENGTH MACHINE

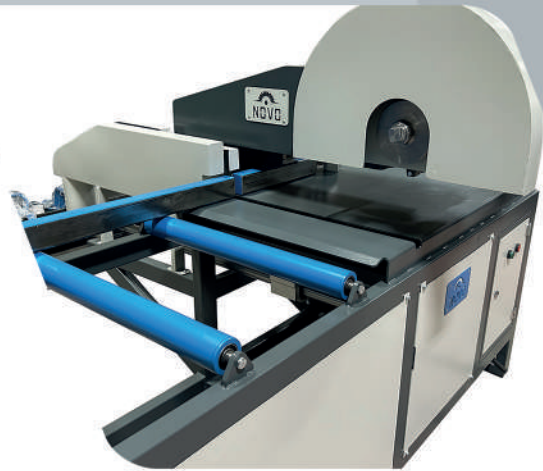



## ÖZELLİKLER / SPECIFICATIONS

Kesme Uzunluğu	Cutting Length	: Max: 6000 mm
Kesme Yüksekliği	Cutting Height	: Max: 150 mm
Kesme Geniřlięi	Cutting Width	: Max: 600 mm
Motor Gücü	Motor power	: 5,5 kW
Toplam Güç	Total power	: 5,5 kW

Not: \* Manuel olarak kesim yapabilme  
\* Opsiyonel olarak otomatik kesim yapabilme  
\* Müřteri isteęine göre yükseklik ve boy uzunlukları opsiyonel olarak ayarlanmaktadır.

Note: \* Ability to perform manual cutting  
\* Optional capability for automatic cutting  
\* Height and length adjustments are available as options according to customer preferences.





# TAKOZ KESME MAKİNESİ WEDGE CUTTING MACHINE

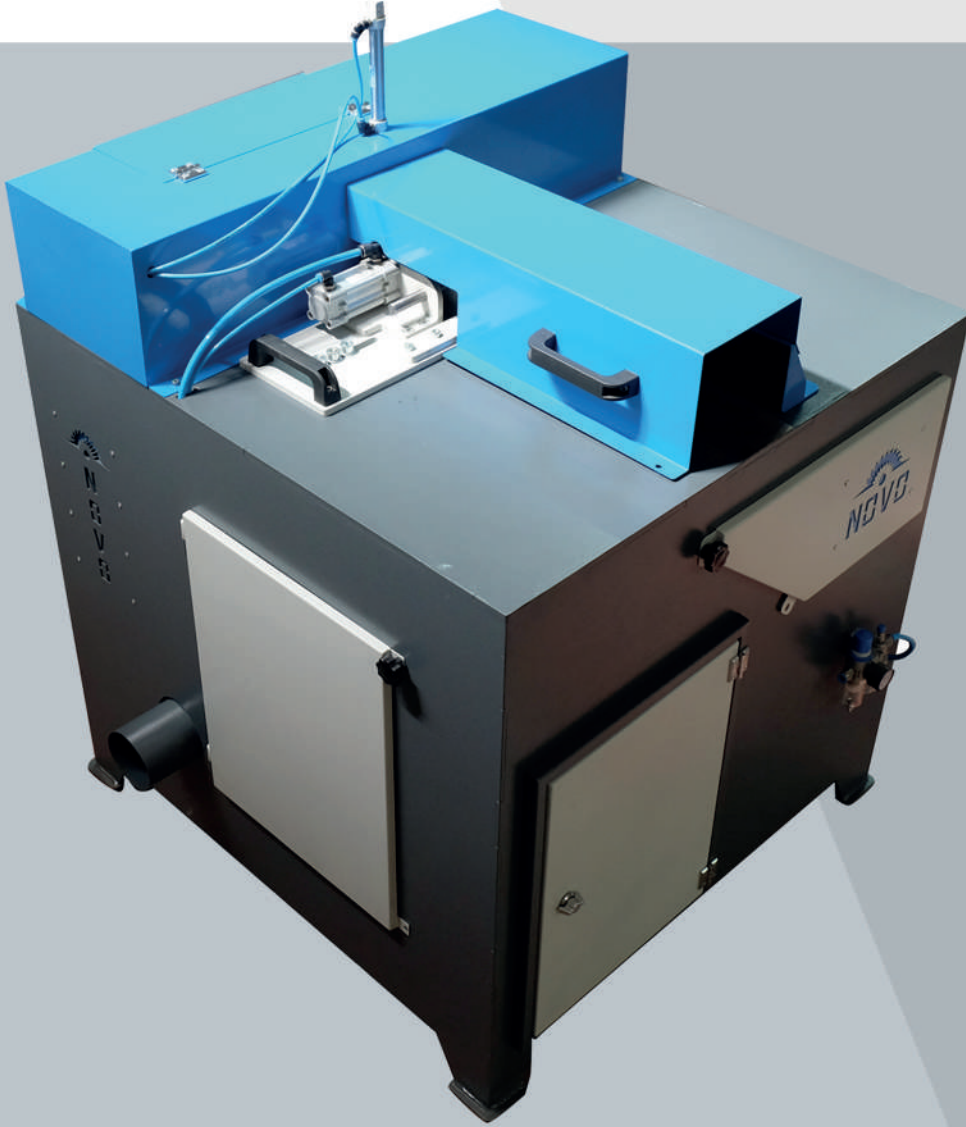

Phone:  
+90 224 716 06 46

Mail:  
info@novomakina.com



## ÖZELLİKLER / SPECIFICATIONS

Kesim Ölçüleri	Cutting Dimensions	: Max. 100x150mm
Kesim Hızı	Cutting Speed	: 50 sd./dk. (min.)
Motor gücü	Motor power	: 4 kW
Toplam Güç	Total power	: 4 kW
Ağırlık	Weight	: 420 Kg.
Testere	Saw	: Ø 500mm

Not: \* Manuel malzeme besleme, İstenilen boyda malzeme kesebilme  
Palet üreticileri için vazgeçilmez makina

Note: \* Manuel feeding. Ability to cut material to desired length.  
Indispensable machine for pallet manufacturers.

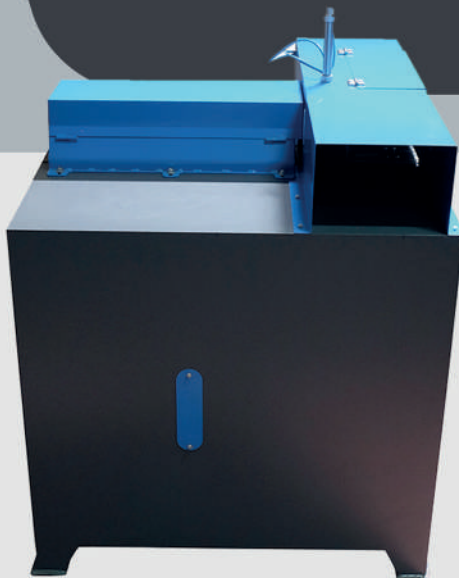



# PAPEL PRESS MAKİNESİ PAPEL PRESS MACHINE



Phone:  
+90 224 716 06 46

Mail:  
info@novomakina.com



## ÖZELLİKLER / SPECIFICATIONS

Makine Ebatları	Machine Dimensions	: 300 cm x 300 cm x 160 cm
Pres Baskı Ebatları	Press Printing Dimensions	: 220cm x 90cm
Pres Strok Ölçüsü	Press Stroke Measurement	: 150 cm
Motor Gücü	Motor Power	: 11 kW
Toplam Güç	Total Power	: 11 kW

Basınç Saati yardımı ile otomatik basınç ayarı yapabilme

Farklı ölçülerde kalıp ayarı yapabilme

Hassas kramayer ile sabitleme

Not: \* Müşteri isteğine göre makine ölçüleri opsiyonel olarak ayarlanmaktadır.

Ability to adjust automatic pressure using a pressure gauge

Ability to set molds in different sizes

Secure fixation with precision clamps

Note: \* Machine dimensions can be optionally adjusted based on customer's request.



# PAPEL PRESS MAKİNESİ PAPEL PRESS MACHINE







## ÖZELLİKLER / SPECIFICATIONS

Makine Ebatları	Machine Dimensions	: 300 cm x 300 cm x 160 cm
Pres Baskı Ebatları	Press Printing Dimensions	: 220cm x 90cm
Pres Strok Ölçüsü	Press Stroke Measurement	: 150 cm
Motor Gücü	Motor Power	: 15 kW
Toplam Güç	Total Power	: 11 kW

Basınç Saati yardımı ile otomatik basınç ayarı yapabilme  
 Farklı ölçülerde kalıp ayarı yapabilme  
 Hassas kramayer ile sabitleme  
 Not: \* Müşteri isteğine göre makine ölçüleri opsiyonel olarak ayarlanmaktadır.

Ability to adjust automatic pressure using a pressure gauge  
 Ability to set molds in different sizes  
 Secure fixation with precision clamps  
 Note: \* Machine dimensions can be optionally adjusted based on customer's request.





# ZIVANA EZME MAKİNESİ TENTLE CRUSHING MACHINE

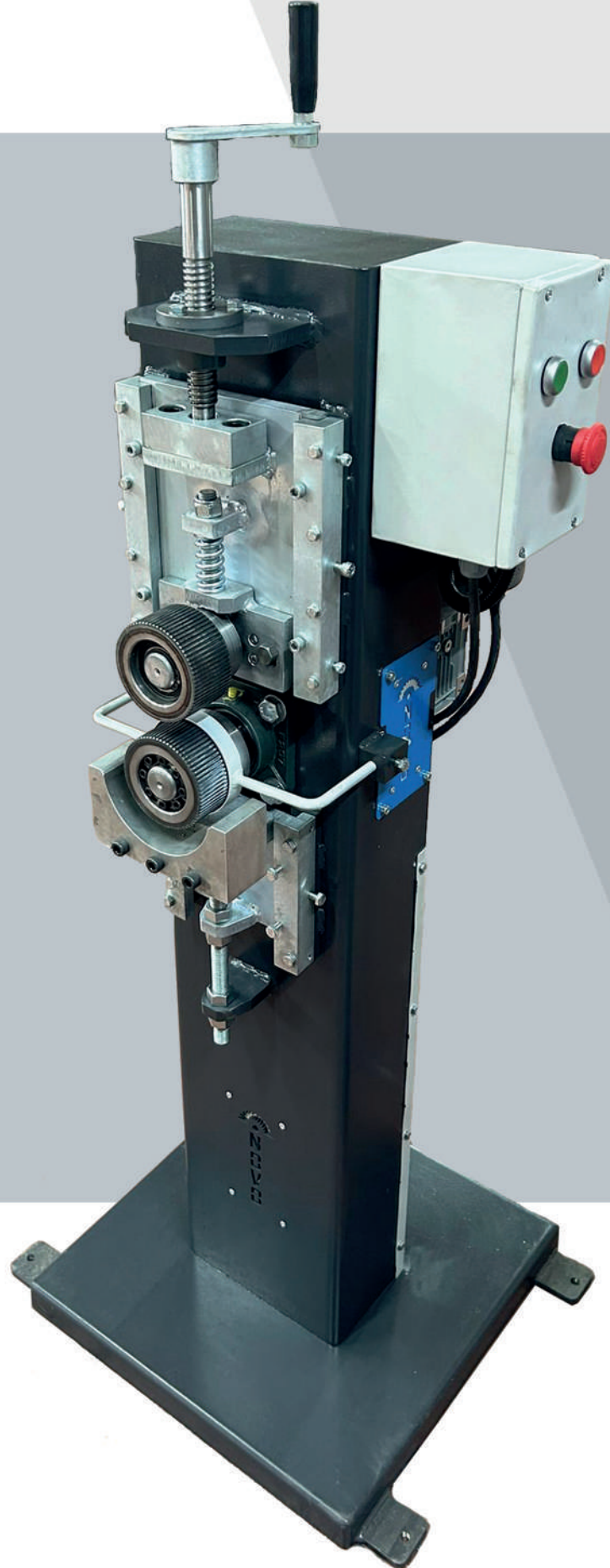

Phone:  
+90 224 716 06 46

Mail:  
info@novomakina.com

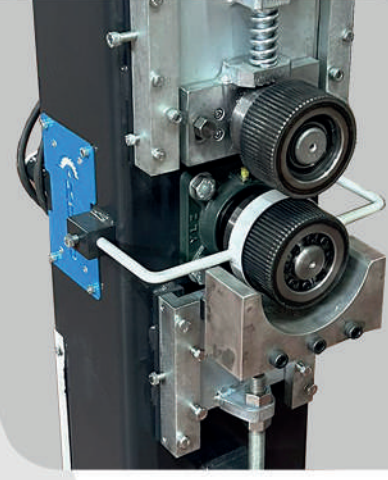
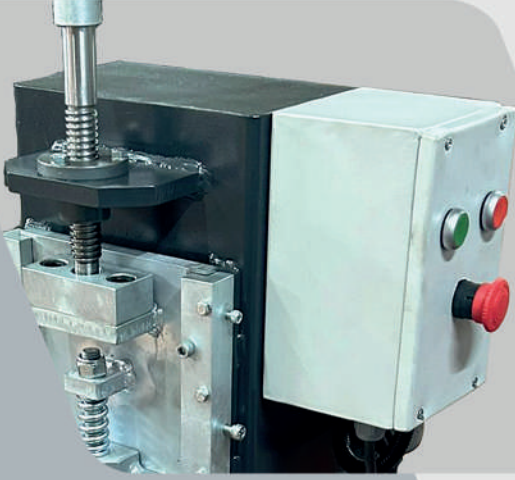

## ÖZELLİKLER / SPECIFICATIONS

Motor Gücü	Motor power	: 0,55 kW
Baskı Aralığı	Print Range	: 1 mm - 100 mm
Baskı Genişliği	Print Width	: Max: 50 mm
Elektrik Kapasitesi	Electrical Capacity	: Max: 0,55 kW

Not: \* Ayarlanabilir baskı aralığı

- \* Sertleştirilmiş ezme ruloları
- \* Redüktör tahrikli sistem
- \* Alüminyum alt baskı
- \* Ayarlanabilir baskı derinliği

Note: \* Adjustable printing range

- \* Hardened crush rolls
- \* Reducer driven system
- \* Aluminum underprint
- \* Adjustable printing depth



# DİKEY SÜNGER KESME MAKİNESİ VERTICAL FOAM CUTTING MACHINE

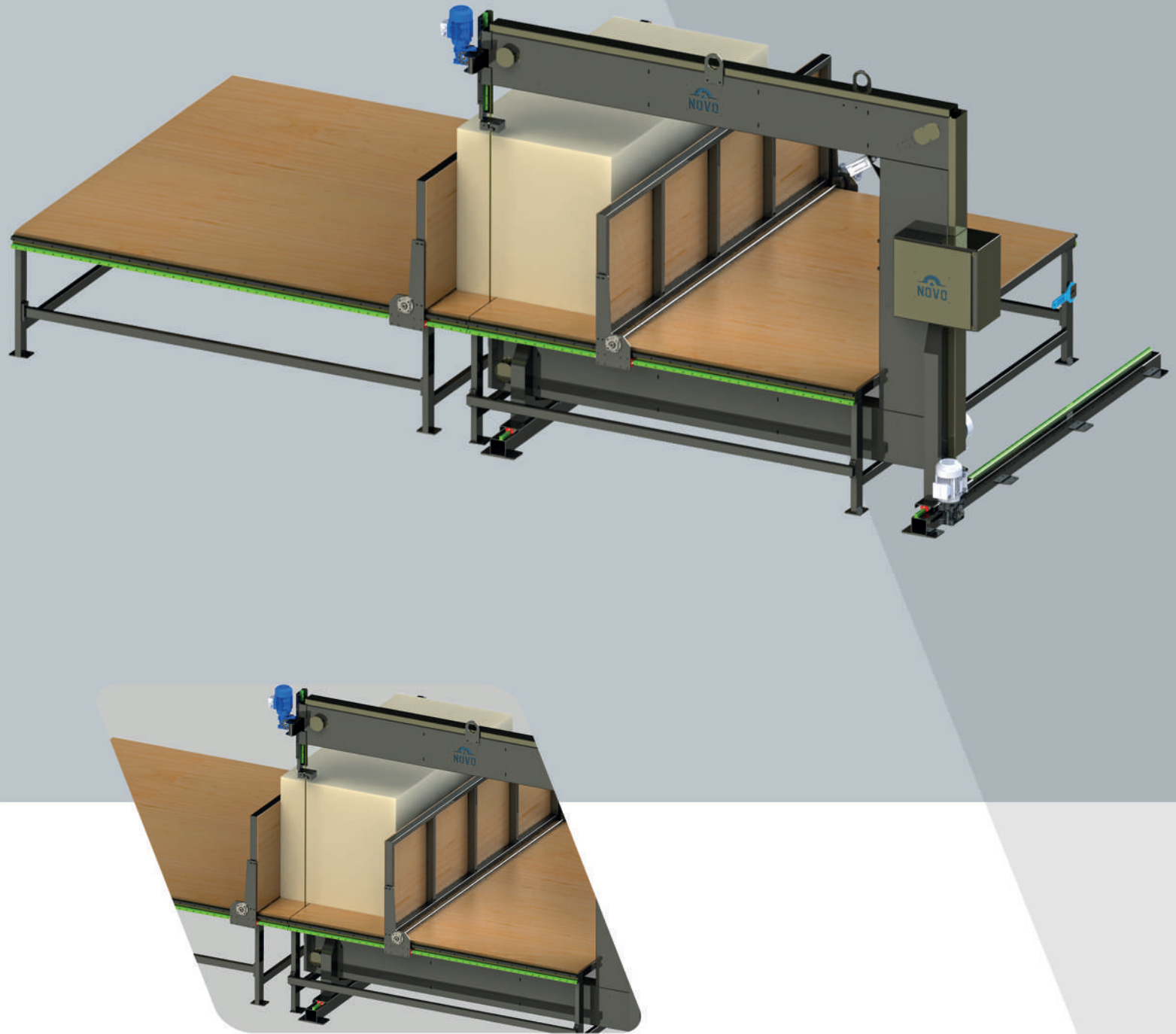

Phone:  
+90 224 716 06 46

Mail:  
info@novomakina.com

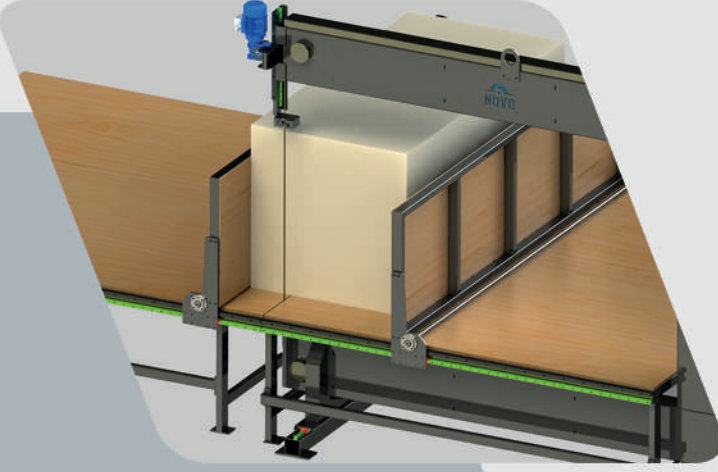

## ÖZELLİKLER / SPECIFICATIONS

Dikey Kesim Yüksekliği	Vertical Cutting Height	: 1200 mm
Dikey Kesim En	Vertical Cutting Width	: 2400 mm
Dikey Kesim Boy	Vertical Cut Length	: 2400 mm
Ana Motor	Main Engine	: 4 kW

### Not:

- \* Çift dayama Cnc Ray Sistem ile hassas ölçüm ayar yapabilmeye
- \* Bıçak : Alman Çatı Diş (2,5 diş)
- \* Ağırlık 1200 Kg

### Note:

- \* Precise measurement adjustment with double support CNC Rail System
- \* Blade: German Roof Tooth (2.5 teeth)
- \* Weight 1200 Kg





## MANUEL PALET AKIM TEZGAHI MANUAL PALLET HITTING MACHINE

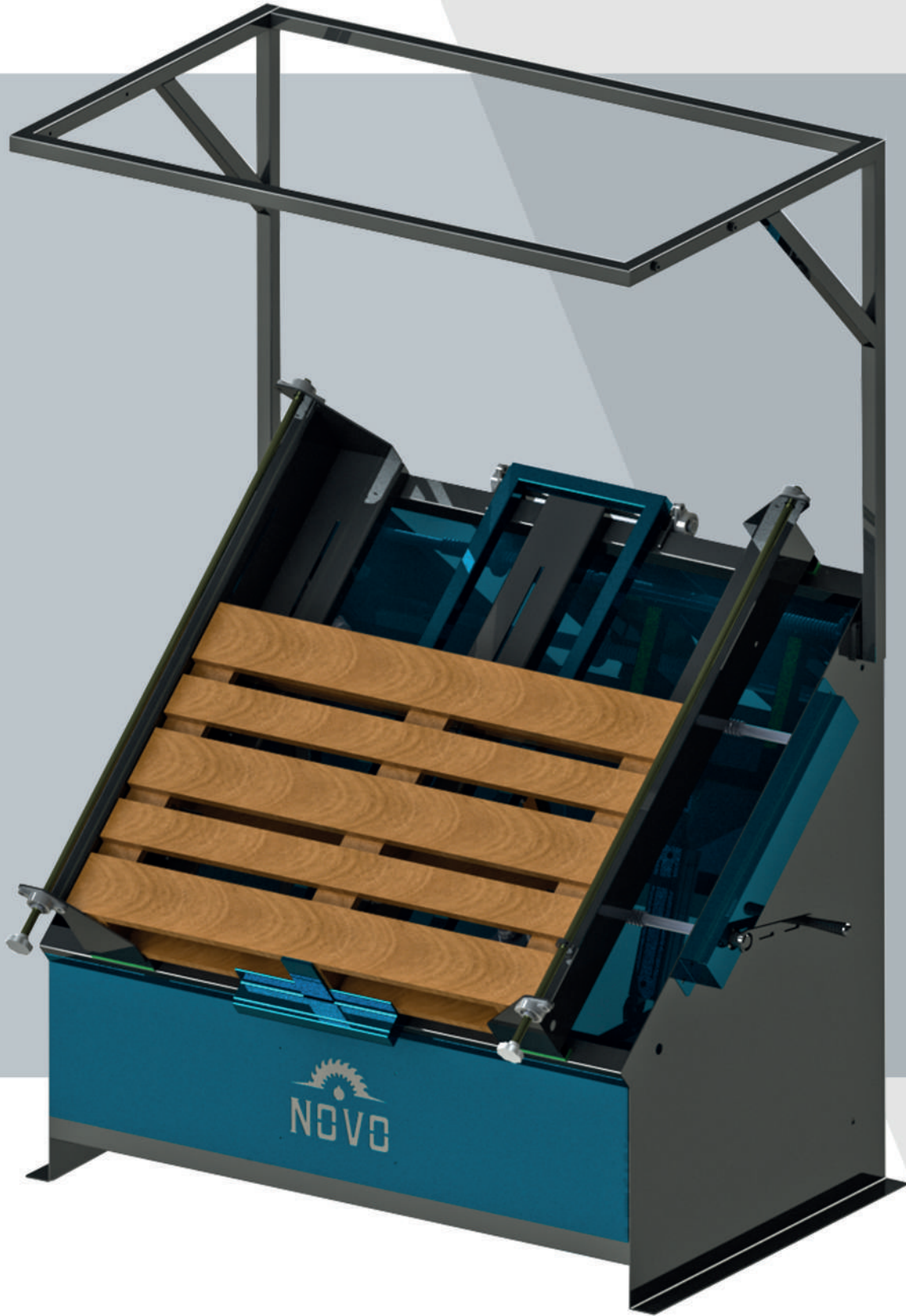

## ÖZELLİKLER / SPECIFICATIONS

Min. Genişlik Palet Ölçüleri	Min. Width Pallet Dimensions	: 800 mm
Max. Genişlik Palet Ölçüleri	Max. Width Pallet Dimensions	: 1400 mm

### Not:

- \* Palet sektörü için manuel palet üretim tezgahları
- \* Set olarak 2 üst çakım ve 1 takoz-ayak çakım olarak yapılır.
- \* Paletin kalıptan kolayca alınabilmesi için pnömatik kaldırma bulunmaktadır

### Note:

- \* Manual pallet production benches for the pallet industry
- \* It is made as a set of 2 top nails and 1 wedge-foot nail.
- \* There is a pneumatic lift to easily remove the pallet from the mold.

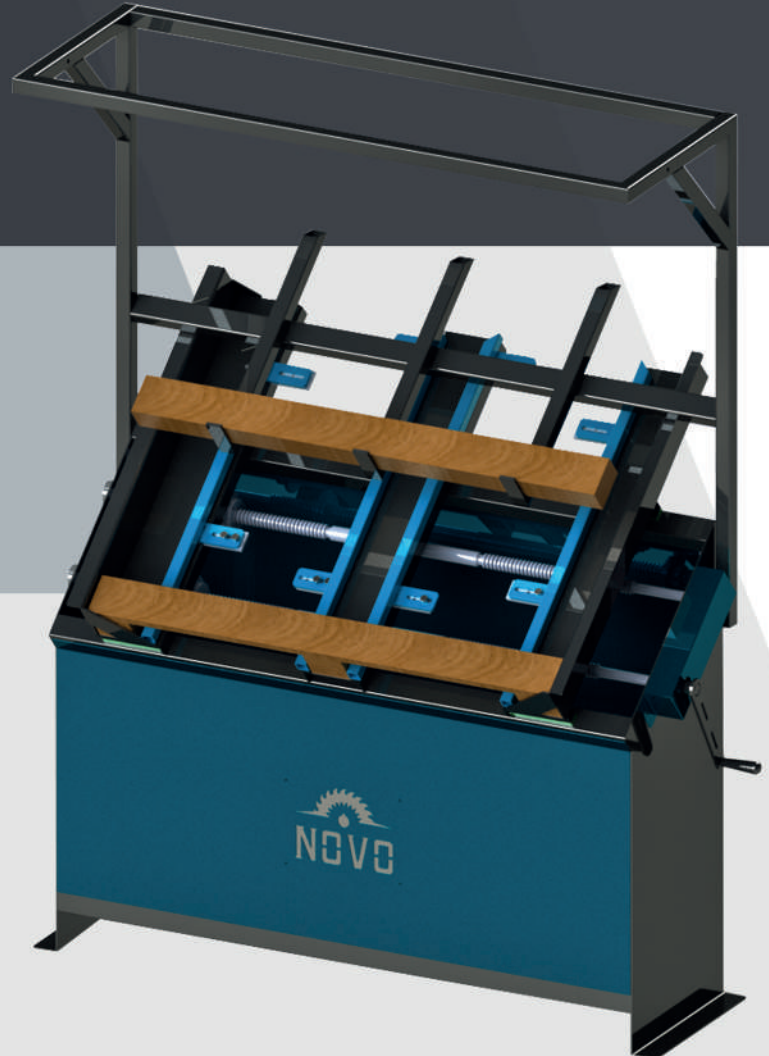



## Kurumsal Bilgi

Novo Makina olarak, ağaç işleme sektöründe müşterilerimize öncü ve kapsamlı çözümler sunmak için var gücümüzle çalışıyoruz. Tasarım, dizayn, üretim, montaj, işletmeye alma, garanti, yedek parça, danışmanlık ve servis hizmetlerimizle, müşterilerimizin ihtiyaçlarına en uygun çözümleri sağlama taahhüdünde bulunuyoruz

Siz de ağaç işleme sektöründe güvenilir, yenilikçi ve müşteri odaklı bir iş ortağı arıyorsanız, sizleri Novo Makina ile çalışmaya davet ediyoruz.

As Novo Makina, we are working hard to provide pioneering and comprehensive solutions to our customers in the woodworking industry. We are committed to providing the most suitable solutions for the needs of our customers with our design, design, production, assembly, commissioning, warranty, spare parts, consultancy and service services.

If you are looking for a reliable, innovative and customer-oriented business partner in the woodworking industry, we invite you to work with Novo Makina.

## Corporate Information

**Web Page:**  
[www.novomakina.com](http://www.novomakina.com)

**Mail / Phone:**  
[info@novomakina.com](mailto:info@novomakina.com)  
+90 224 716 06 46

**Address:**  
Mesudiye Mah. Yıldırım Cad.  
No:49 İnegöl / BURSA